

Conergy SolarFamulus II



CONERGY



Installation manual



SolarFamulus II – for universal use on flat roofs

Table of Contents

1	Introduction	1
1.1	Short description	1
1.2	Intended use	1
1.3	Standards and technical directives	1
1.4	About this manual	1
2	Safety	2
2.1	Basic safety instructions	2
2.2	Working on roofs	2
2.3	Warnings	2
2.4	Operator’s responsibilities	3
3	Technical description	4
3.1	System overview	4
3.2	Scope of delivery	5
3.3	Technical specifications	6
3.4	Operating conditions	6
4	Planning of the module field	6
4.1	Dimensions	6
5	Important mounting information	8
5.1	Mounting aids and required tools	8
5.2	Additionally required materials	8
6	Installation	8
6.1	Preparation work	8
6.2	Installing the system	9
6.3	Installing the modules	12
6.3.1	Portrait installation	12
6.3.2	Landscape installation	13

1 Introduction

1.1 Short description

The Conergy SolarFamulus II flat roof system is a robust mounting system for PV modules on flat roofs. It consists of aluminium triangles, aluminium support rails and all necessary accessories for attaching the modules to the rails and connecting the components to one another. Further components such as roof fixation kits or back plates are also available. With the SolarFamulus II, both portrait and landscape module mounting are possible.

1.2 Intended use

The Conergy SolarFamulus II flat roof system is to be used for the roof installation of PV modules only. Any other use is considered improper.

The observance of the information in these assembly instructions is a part of proper use. The manufacturer is not liable for damage that results from the non-observance of assembly instructions, in particular the safety information, or from the improper use of the product.

1.3 Standards and technical directives

When planned correctly, SolarFamulus II fulfills the following standards and technical directives:

- Eurocode 9 — DIN V ENV 1999-1-1: Design of aluminium structures
- DIN 1055 — Actions on structures: Basis of design, safety concept and design rules

1.4 About this manual

Subject

This manual details the installation and assembly of the SolarFamulus II flat roof system. The illustrations in the manual show the portrait mounting procedure for framed modules. Should landscape mounting differ from portrait mounting, this will be clearly emphasised. Some additional components that are repeatedly used are also indicated. No description is included for materials for special substructures that may be required to accommodate the constructional conditions of the building in addition to standard materials. These are always specially manufactured and documented separately.

User group

This manual is intended for qualified personnel with a basic knowledge of mechanics, hand tools and mechanical skills.

2 Safety

2.1 Basic safety instructions

The following basic safety instructions and the warning notes are an essential part of this manual and are of fundamental importance for handling the product.

- Ensure that the product corresponds to the static requirements on-site prior to every assembly and installation.
- Ensure that the building corresponds to the increased static requirements due to the PV unit, prior to every mounting and installation.
- Observe occupational health and safety regulations of the employer's liability insurance association.
- Wear a hard hat, protective gloves and safety shoes.
- A second person must be present during the entire installation process, to give assistance in the event of an accident.
- A copy of this installation manual must be kept in the direct vicinity of the unit.

2.2 Working on roofs

When working on roofs, note the following instructions:

- Pay attention to accident prevention regulations for working on roofs. If appropriate, use a barrier to protect against falling parts.
- In line with accident prevention regulations, work on roofs should be carried out using safety harnesses for individuals or safety scaffolding.
- Observe the relevant local safety regulations.
- Before stepping on to the roof, check the load-bearing capability of all parts which are under stress.

- Use fall protection.
- Use protective equipment to guard against falling even when carrying out short jobs.
- Do not carry materials on to the roof via ladders, but rather use suitable lifting gear.

2.3 Warnings

The warning notes used in this manual identify safety related information. They consist of:

- Warning symbol (pictograph)
- Indicator word to denote the danger level
- Information about type and source of the danger
- Information about possible consequences if the danger is not observed
- Measures for avoiding the danger and for preventing injuries or property damages

The heading of the warning notes identifies one of the following danger levels:



DANGER

Denotes a major risk, failure to observe which could lead to serious injury or death.



WARNING

Denotes a potentially dangerous situation which may lead to moderate to serious physical injury and property damage.



CAUTION

Denotes a potential risk which may lead to physical injury and property damage.

2.4 Operator's responsibilities

The system operator has the following safety-relevant responsibilities:

- Ensure that the installation of the system is only performed by persons with manual skills and basic knowledge of mechanics.
- Ensure that the assigned installation personnel can evaluate the work assigned to them and can recognize possible dangers.
- Ensure that the persons commissioned are familiar with the system components.
- Ensure that the installation manual is accessible during the assembly. The mounting instructions are an integral part of this product.
- Ensure that the mounting instructions and in particular the warnings have been read and understood by the authorized installation personnel prior to assembly.
- Ensure that the permissible conditions of use (see chapter 3.4, page 6) have been upheld. Mounting Systems GmbH will not be held liable for damage which results from a violation of these conditions.
- Ensure that the roof construction has the required load-bearing capacity, in particular in the vicinity of the force transmission points.
- Ensure that the durability of the mounted connections and the roof attachments are guaranteed.
- Ensure that any necessary roof penetrations are professionally sealed.
- Ensure that the appropriate lifting equipment is used for the mounting process.
- Ensure that only original components are used, also in case of replacement.

Otherwise the warranty claim is void.

3 Technical description

3.1 System overview

All system components are described below. The design of the individual system components may vary.

They are dependent on:

- Type of roof,
- Type of module,
- Number of modules and
- The conditions on site.

Components:

- a Triangle (shown here with foot brackets)*
- b Triangle (shown here with ground rail)*
- c X-Stone*
- d Base rail 13/58*
- e Splice 13/58 (not visible)*
- f Telescoping end piece 13/58*
- g Diagonal strut*
- h SolRec base plate (optional accessory)*
- i Module end clamp for landscape installation*
- j Module clamp*
- k Module end clamp for portrait installation*

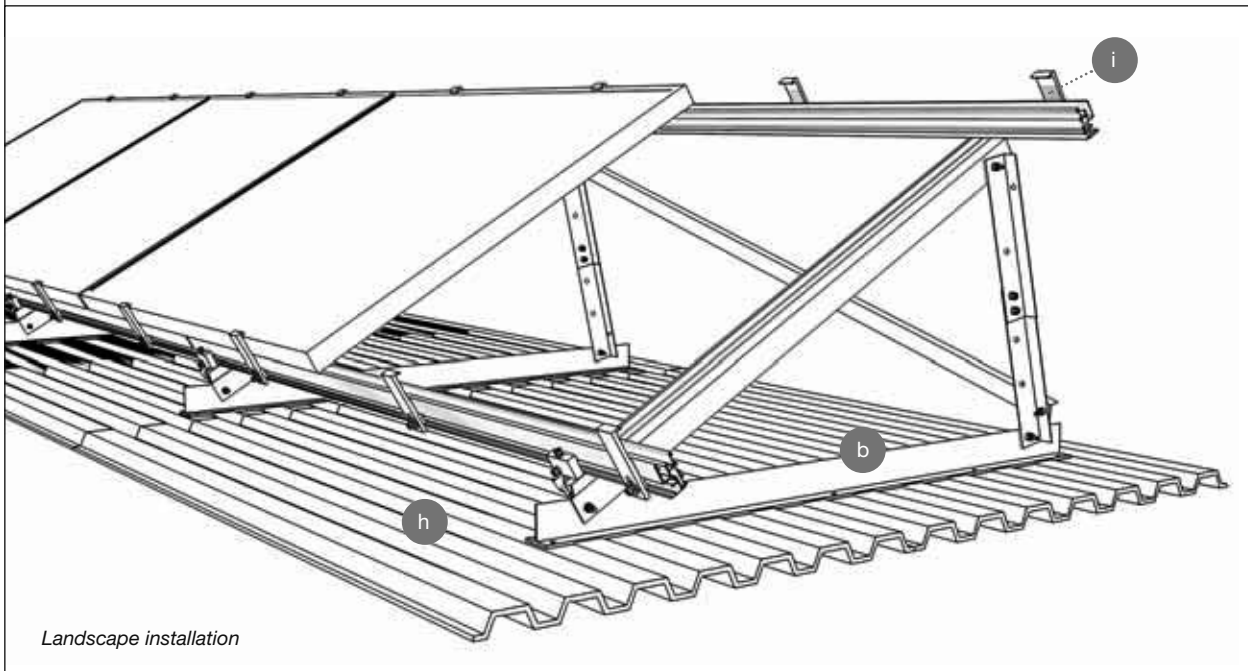
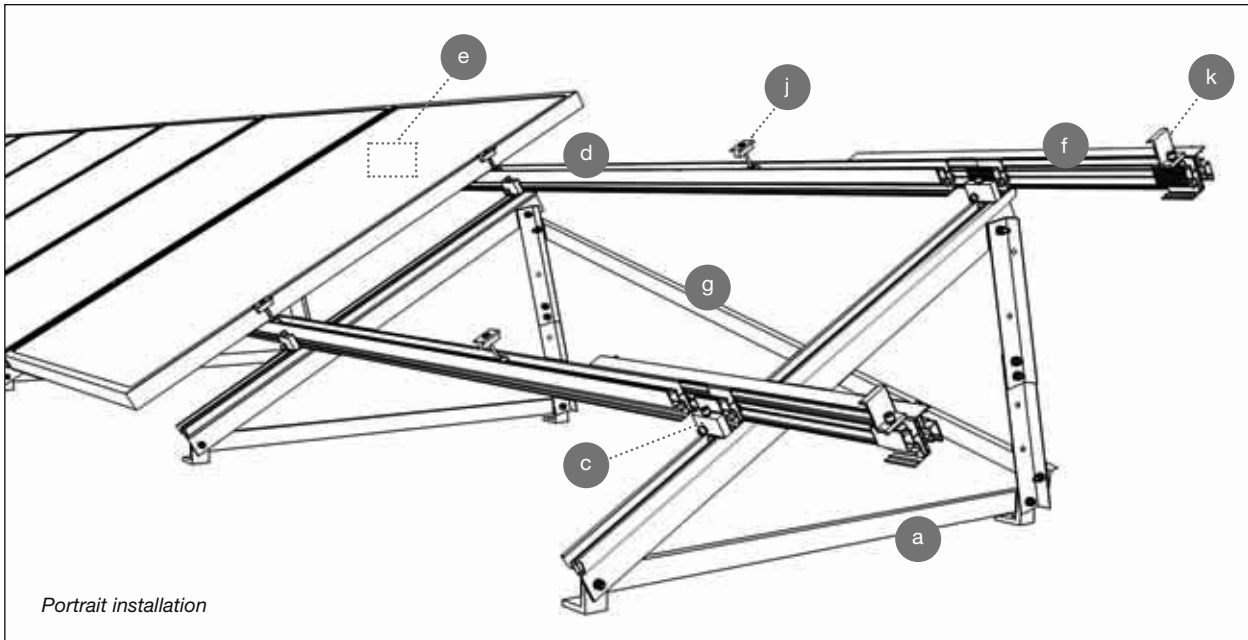

3.2 Scope of delivery

All system parts and requisite small parts which are required for installation are included in the delivery. The precise scope of supply will depend on the size and number of PV modules which you specify when ordering. No description is included for materials for special substructures that may be required in addition to standard materials to accommodate the constructional conditions of the building.

- a** Triangle (shown here with foot brackets)
- b** Triangle (shown here with ground rail)
- c** X-Stone*
- d** Base rail 13/58
- e** Splice 13/58
- f** Telescoping end piece 13/58
- g** Diagonal strut
- h** SolRec base plate (optional accessory)
- i** Module end clamp* for landscape installation, module frames between 32 and 56 mm
- j** Module clamp*
- k** Module end clamp* for portrait installation for frame heights of 35, 43, 46 and 50 mm
- l** Module end clamp* for portrait installations for frame heights of 24.5–51 mm
- m** Laminate clamp*
- n** Laminate end clamp*
- o** Back plate (optional accessory)
- p** Concrete anchor (optional fixation material)
- q** Hanger bolt (optional fixation material)
- r** Bolt connection, consisting of Allen bolt M8 x 20, self-locking nut M8 and 2 washers
- s** Anti-slip device for modules, consisting of nut M6 and Allen bolt M6 x 20
- t** Quickstone profile nut (not an individual component, but pre-assembled on the components marked *)

* with Quickstone



3.3 Technical specifications

Support profile, base rails	Extruded aluminium (EN AW 6063 T66)
All other profiles	Aluminium (EN AW 6060 T6)
Accessories	Stainless steel (V2A)
Back plate	Aluminium (EN AW 5005)
SolRec base plate	PE

3.4 Operating conditions

Application range	Flat roof
Roof pitch	0 – 5°, greater pitch subject to prior verification
PV module	Framed, unframed
Roof construction	The suitability of the entire roof construction, in particular at the load transfer points of the mounting system, must be examined for static, insulation, leak tightness, and fire protection requirements prior to installation of the PV system.
Permissible roof load	Must be specifically checked for each project.
Attachment method	Must be specifically checked for each project.
Triangle and support rails	Up to 1,900 PA for a 2.5 m ² surface per triangle and a roof pitch up to 5°
Max. row length	12 m
Distance between the triangles	Depending on project planning, portrait installation up to approx. 1.5 m, landscape installation up to approx. 1.8 m

4 Planning of the module field

4.1 Dimensions

In the following, the dimensions of the mounting system will be given. The exact spacing between the triangles is project-specific and must be individually defined in the planning phase.

Width of the unit: Number of horizontal modules x (module width + 19) + 31mm; maximum 12 m



Notice:

The material expansion of a 12 m-row can be approx. 2 cm. Therefore, a minimum distance of 10 cm between the rows is recommended. Furthermore, for large systems, it is wise to leave more space at regular intervals as maintenance paths.

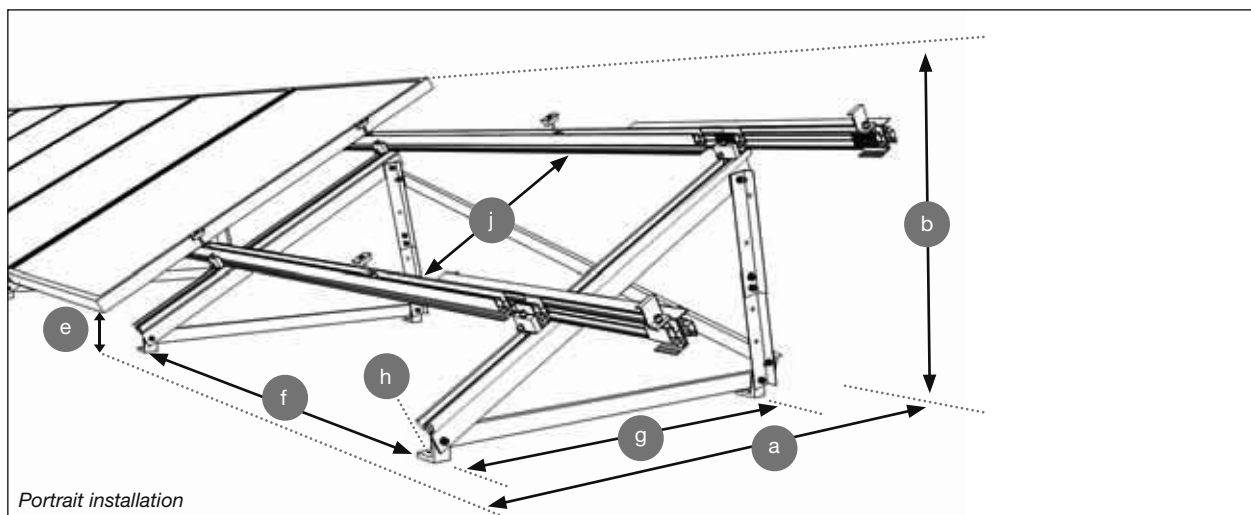

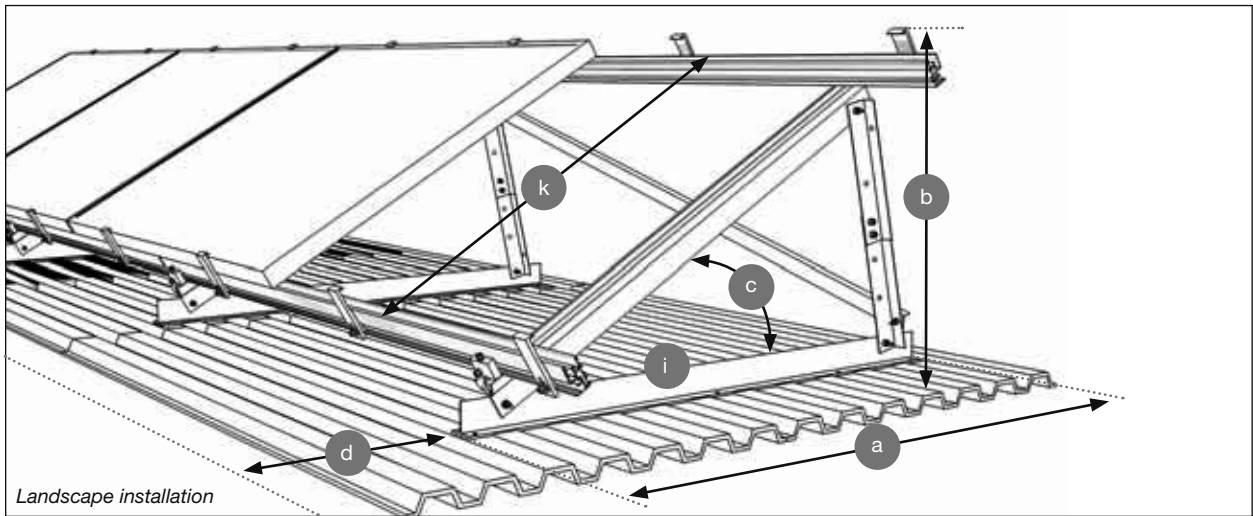

- a** Depth of the frame unit: see table A below
- b** Height of the frame unit: see table B below
- c** Pitch: 20°, 25°, 30°
- d** Distance between the rows: according to project plan
- e** Distance to ground: at least 8 cm, depending on module positioning
- f** Distance between the triangles: according to plan, portrait mounting up to approx. 1.5 m, landscape mounting up to approx. 1.8m
- g** Distance between the foot brackets of the triangle: 955 mm / 1260 mm, depending on selected triangle type (model A/B)
- h** Drill hole size in the foot brackets: 11 mm or 13 mm, depending on selection
- i** Ground rail, hole pattern for triangle models A and B: see illustration I below
- j** Distance between the base rails for portrait installation: Distance of the clamp points as recommended by the module manufacturer (usually marked by the drill holes in the module frame, approx. ½ the module length).
- k** Distance between the base rails for landscape installation: Distance of the outer edges of the rails = module width

Depth of the unit, including module

A

Pitch	Landscape installation	Portrait installation
20°	995 mm	module length x 0.94; at least 995 mm
25°		module length x 0.91; at least 995 mm
30°		module length x 0.87; at least 995 mm

Height of the frame unit, including module

B

Pitch	Landscape installation	Portrait installation
20°	534 mm	(module length x 0.34) + 80 mm; at least 534 mm
25°	615 mm	(module length x 0.42) + 80 mm; at least 615 mm
30°	692 mm	(module length x 0.50) + 80 mm; at least 692 mm

Hole pattern: Ground rail A

I

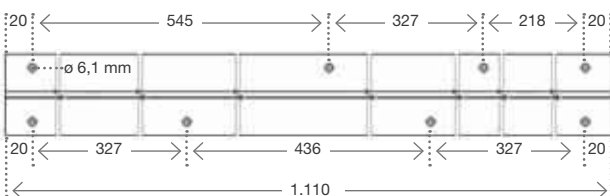

Hole pattern: Ground rail B

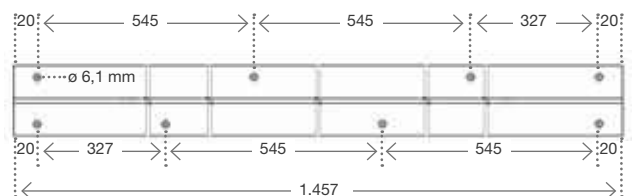

All dimensions in mm

5 Important mounting information

5.1 Mounting aids and required tools

You will need the following tools to install the system:

- 6 mm Allen key
- Combination wrenches 13
- Folding rule / tape measure
- 9 mm metal drill bit

Appropriate tools for the respective roof mounting variations, e.g.:

- For riveting onto SolRec floor plates: 6.1 mm drill bit, rivet gun
- For attachment with fix anchors into concrete: 12.5 mm concrete drill bit, hammer

5.2 Additionally required materials

Depending on the system plan, the following additional materials may be necessary:

- Suitable fixation material for roof
- Material for weighting as ballast, for example gravel, concrete slabs or other
- Suitable protective mats to protect the roof surface.

6 Installation

6.1 Preparation work



DANGER

Potentially mortal danger from falls and falling objects

- Protect yourself against falling.
- Do not remain in the danger zone.
- Wear a hard hat.
- After the assembly is complete, ensure secure positioning of the mounting system and the modules.

1 Preparing the fixation points

- Define and mark the fixation points, and/or the planned substructure according to plans, and prepare for installing the triangles.

2 Preparing the triangles

- Unfold the triangles and pre-mount both of the support elements with 2 bolts each (self-locking nut M8, 2 washers and M8 x 20 Allen bolt) at the desired angle (tightening torque 8 Nm).
- Tighten all of the screw connections on the triangle (tightening torque 8 Nm).

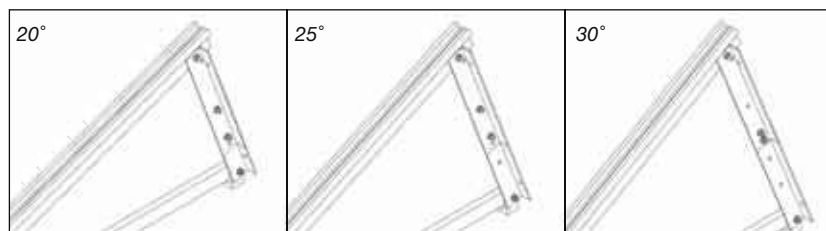

CAUTION

Material damage from improper mounting

Improperly fastened triangles can bend or collapse.

- Carry out all new bolted connections using the abovementioned materials (bolts, washers and nuts).
- After installation, ensure that all bolted connections are tight.

3 Mounting the anti-slip protection (only for portrait installation)

- Attach one bolt with M6 nut in each of the lower drill holes of the module frame as an anti-slip protection, and tighten them by hand.

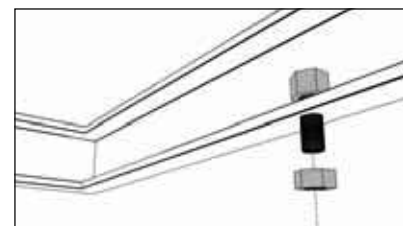

6.2 Installing the system

1 Mounting the triangles

- While maintaining the planned spacing, arrange the triangles so they are parallel, and fix them with the designated connecting materials.

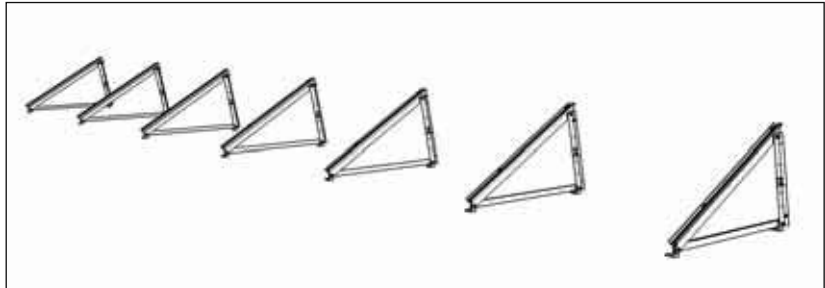
**WARNING****Material damage due to inappropriate material selection**

Inappropriate fixation material can cause the triangles to rip out, roof damage and leakage.

- Select appropriate fixation material according to the location, roof state, and system design.

**WARNING****Material damage from improper mounting**

Improperly fixed triangles can rip out and result in leaks.

- All attachments should be of professional quality.
- After mounting, ensure that the fixation is correct.

2 Fixing the X-stones

- Fix two X-stones per triangle (see point 4.1 Dimensions) to the support rail of the triangle at the specified points. Take care to observe the differing alignment of the X-stones for portrait or landscape installation (see illustration on the right).
- Insert the Quickstone into the profile channel so that the form of the Quickstone fits perfectly into the profile. The bolt may not protrude beyond the lower edge of the Quickstone.
- Fasten the Quickstone loosely with 2 bolt turns.
- Put the X-stone in the desired position and line it up transversely to the support rail.
- Tighten the bolt just enough so that the X-stone does not slide down. Do not tighten completely.

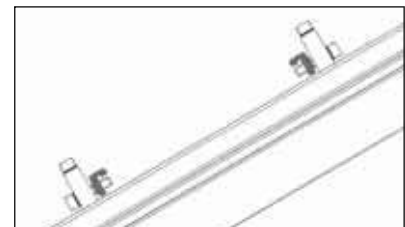
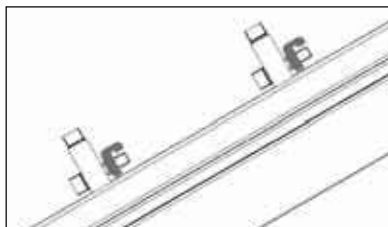
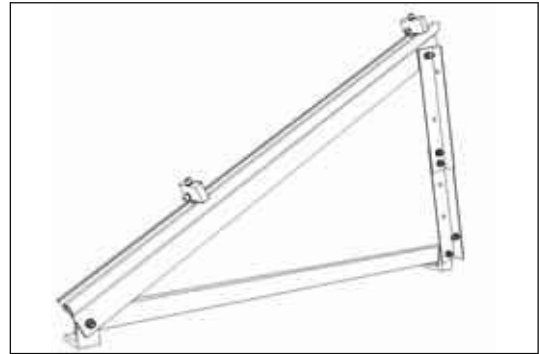
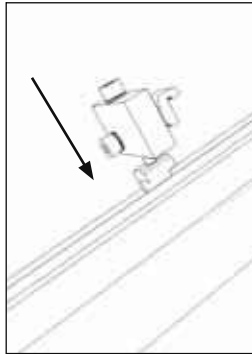

Portrait installation

Landscape installation

**CAUTION****Material damage due to improper mounting**

Improperly fastened X-stones may slip or rip out.

- All Quickstone connections must be mounted according to instructions.
- After mounting, check that the bolted connections are tight.

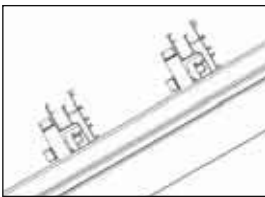

Portrait installation

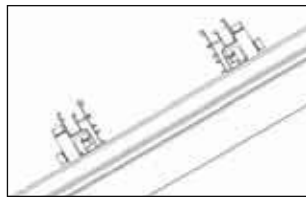

Landscape installation

3 Install base rail

- Mount 2 horizontal base rail sections per row of triangles.
- Align and position the rails according to the selected module dimensions (distance between the rails, see page 7 point j and k).
- Lay the rails with the smooth side down on the triangles and fasten them loosely to the vertically-mounted x-stones on the side.
- Take care to observe the differing alignment of the rails for portrait or landscape installation (see illustration on the left).
- Align the rails and subsequently tighten the vertical and horizontal X-stone bolts finally (tightening torque 8 Nm).

4 Connecting the individual rails

- The splice should be slid in half-way from the side, on the back side of the profile rail.
- Slide the next profile rail into the splice.
- Tighten both bolts of the splice (tightening torque 8 Nm).

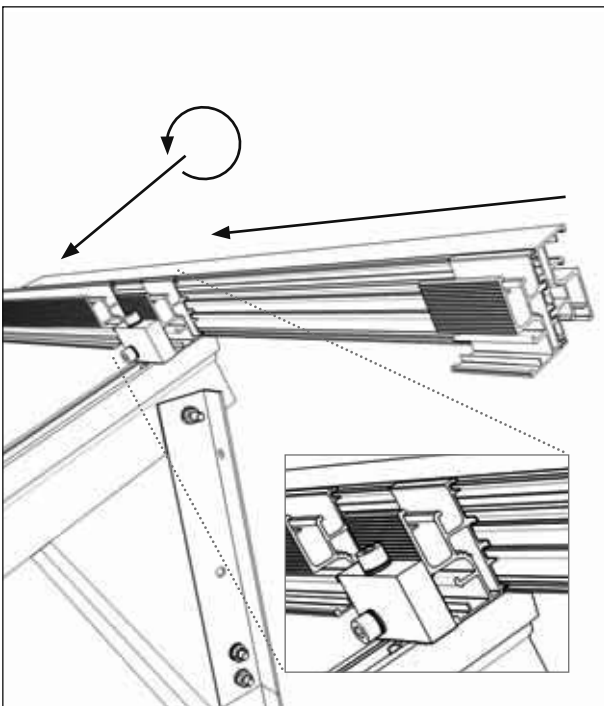
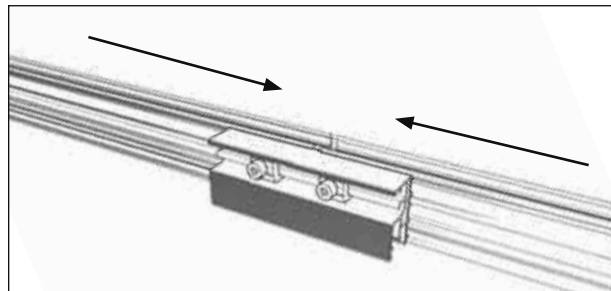

5 Mounting the telescoping end piece (inclusion is dependent on design)

- If intended, slide a telescoping end piece into the base rail at the end of each rail section, but wait to tighten.
- If applicable, mount the flexible element of the telescoping end piece onto the X-stone of the last triangle.
- After the precise adjustment to the length of the module surface area, fix the telescoping end piece. This is done by, tightening the bolt on the end of the telescoping end piece facing the module surface area (tightening torque 8 Nm).



TIP: It is best not to pre-calculate and adjust the exact position of the telescoping end piece, but instead to do the exact positioning and final mounting while fixing the last module.

6 Attaching the diagonal struts

- Mount 2 diagonal struts per unit on the left and right ends of the row.
- Loosely mount one end of the diagonal in the lowest pre-drilled bore hole of the strut to the outside triangle with a self-locking nut M8, 2 washers and an allen bolt.
- Point the strut diagonally to the next triangle in the row and mark the exact position of that triangle's upper-most bore hole on the diagonal.
- Drill a hole with diameter of 9 mm at the marked location.
- Fix the second end of the diagonal.
- Tighten both diagonal connections finally (tightening torque 8 Nm).
- If necessary, shorten any protruding ends of the diagonals (purely for appearance purposes).

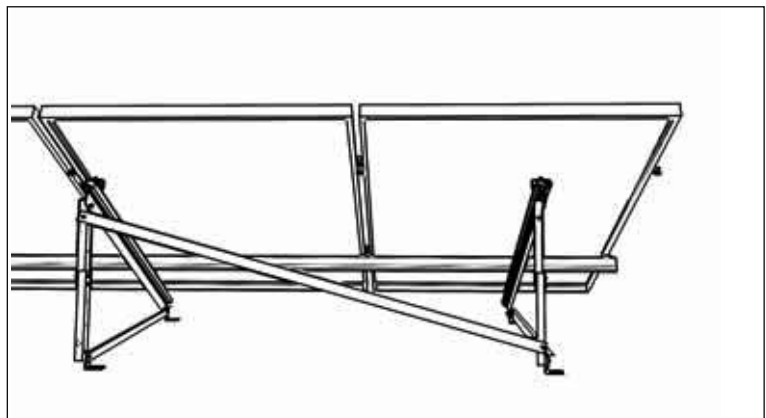
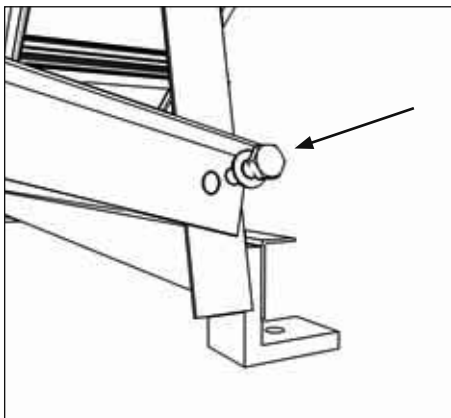
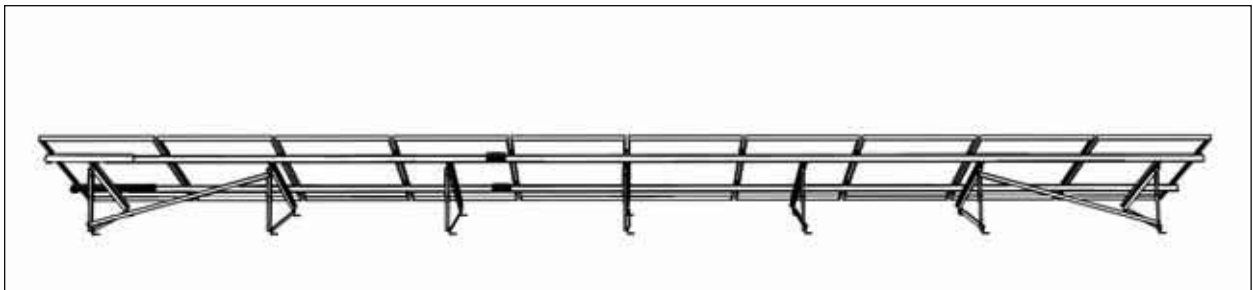

7 Attaching the back plate (alternative to the diagonal struts)

- Hold the back plates against the triangles from behind, and fix them to the triangle supports with two drill screws per triangle.
- Allow the back plates to overlap by 5 cm.

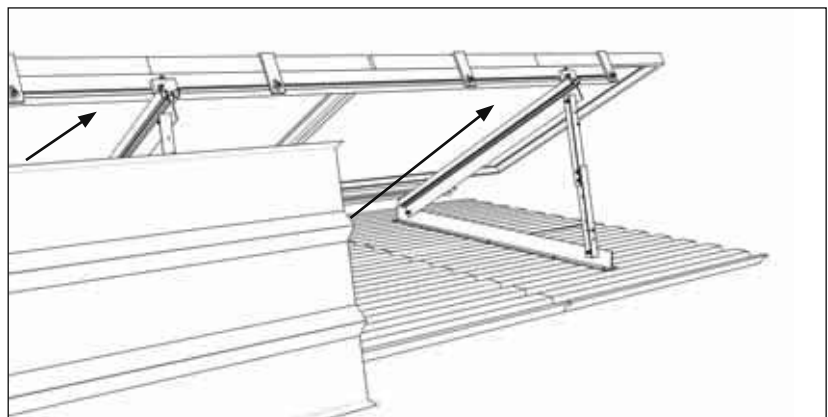

6.3 Installing the modules

6.3.1 Portrait installation

1 Module positioning

- Place the modules on the rails so that the slip-guard bolts are in the lowest rail channel.

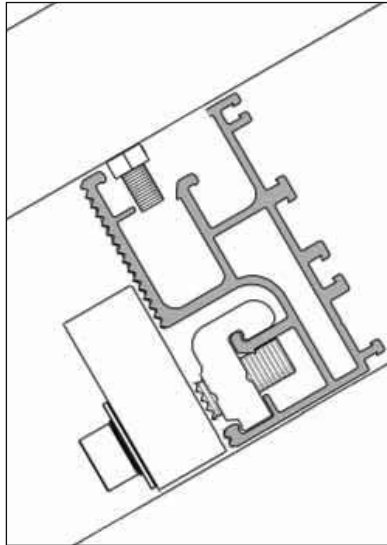
**CAUTION****Material damage due to improper mounting**

- Improperly fastened module (end) clamps may rip out.
- All Quickstone connections must be mounted according to instructions.
 - After installation, ensure that the bolted connections are tight.

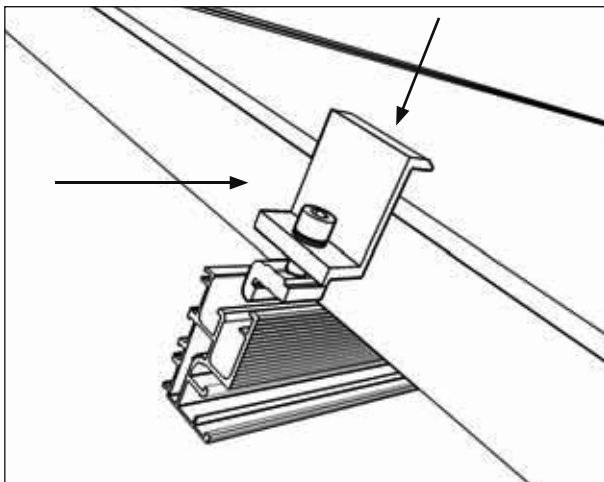

2 Attaching the outer modules

- Insert the Quickstone of the module end clamps in the top channel of the base rail (the bolt may not protrude on the under side of the Quickstone) and fasten them loosely.
- Before tightening, push the modules under the module clamps and align them.
- Tighten the module end clamps (tightening torque 8 Nm).

3 Attaching the inner modules

- Insert the Quickstone of the module clamp into the top rail channel of the base rail, slide them on to the previously mounted module and fasten loosely.
- Slide the second module onto the module clamp, align it, and tighten the bolts (tightening torque 8 Nm).



When installing laminates, special laminate end and/or laminate middle clamps must be used. The installation procedure is identical. Slide the laminate between the rubber lips of the laminate end clamp before tightening.

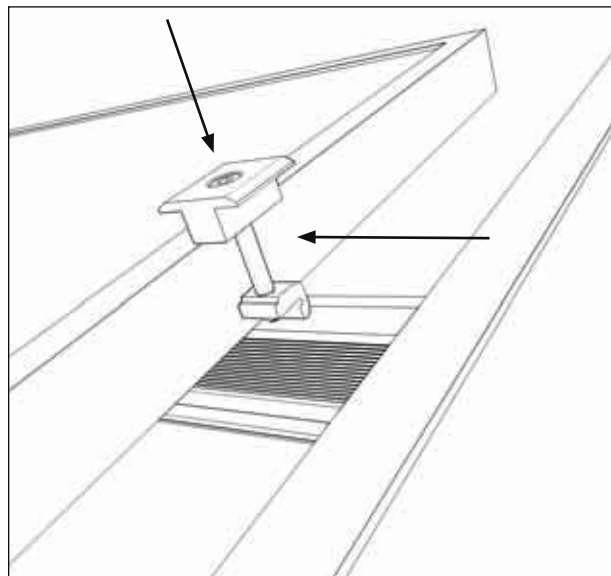

6.3.2 Landscape installation

- 1 Mounting the lower module end clamps for landscape installation
 - Fix two module end clamps per module to the lower base rail.
 - Insert the Quickstone of the end clamp into the side channel of the rail and fasten loosely.
 - The distance between the clamps should be based on the optimal clamping points of the respective module specified by the manufacturer (usually marked by the drill holes in the module frame, approx. $\frac{1}{4}$ of the module length from the right and the left).

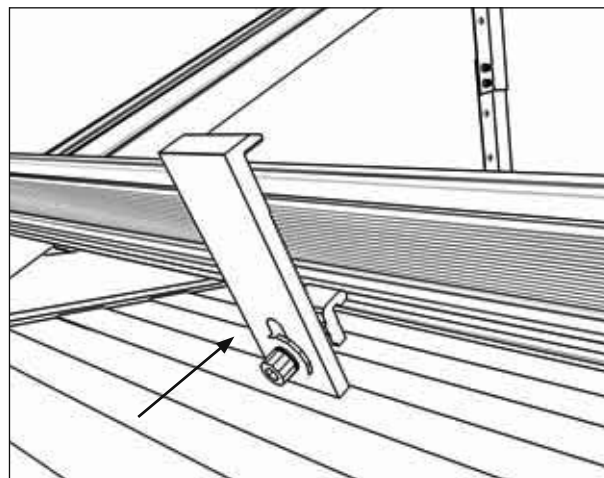
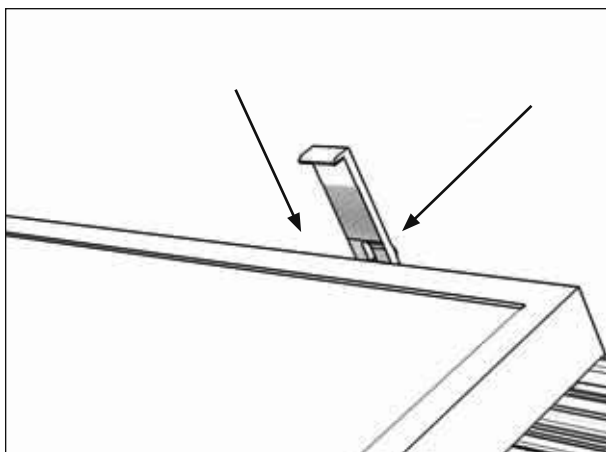

2 Module positioning

- Place the module in landscape position onto the loosely mounted lower module end clamps.
- Align the modules. It is not necessary to leave any space between the individual modules.
- Adjust the height of the lower module end clamp by means of the slotted hole so that the clamp lies directly on the module. Finally tighten the clamps in this position (tightening torque 8 Nm).

3 Mounting the upper module end clamps

- Make sure that the upper edge of the upper rail row is flush with the modules and that the side rail channels and the X-stones point upwards (see illustration page 10, point 3). If necessary, correct the positioning of the base rail.
- Mount two end clamps per module to the upper base rail, parallel to the positioning of the lower end clamps and tighten finally (tightening torque 8 Nm).

**CAUTION****Material damage due to improper mounting**

Improperly mounted module end clamps may slip or rip out.

- All Quickstone connections must be mounted according to instructions.
- After installation, ensure that the bolted connections are tight.

For further information:

www.conergy.com

Subject to technical modifications without notice.
2011 © Conergy