

Installation manual

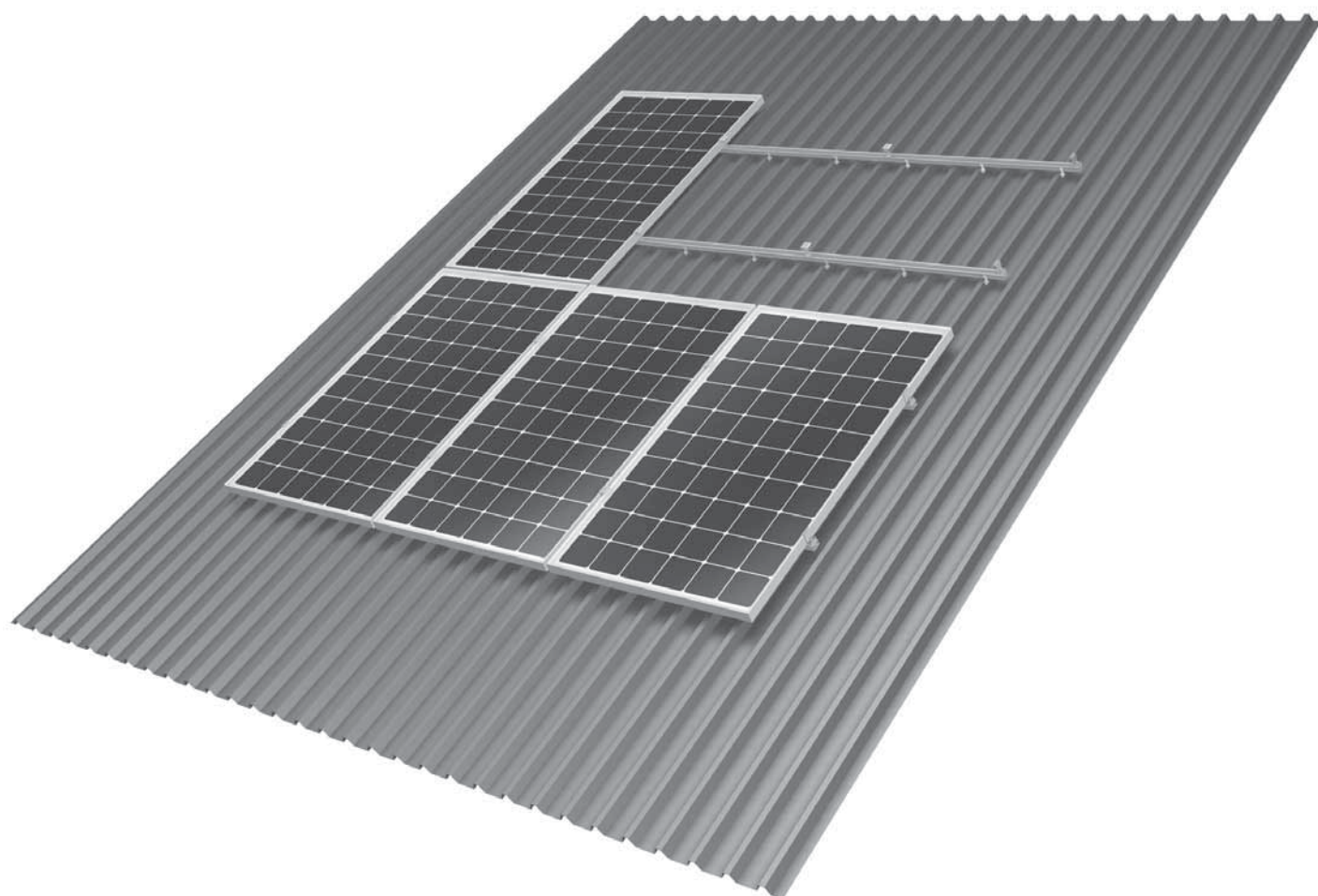

CONERGY

Conergy SunTop Trapeze



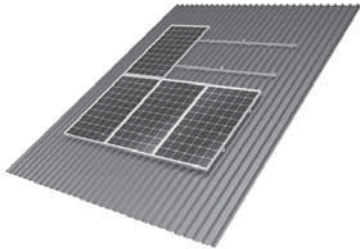

Conergy SunTop Trapeze - innovative solution for metal roofs

Table of Contents

1	Introduction	1
1.1	Short description	1
1.2	Intended use	1
1.3	Standards and guidelines	1
1.4	About these instructions	1
2	Safety	2
2.1	Basic safety information	2
2.2	Information regarding working on roofs	2
2.3	Warnings	2
2.4	Operator's responsibilities	3
3	Technical description	4
3.1	System overview	4
3.2	Scope of delivery	5
3.3	Technical specifications	6
4	Planning the module area	7
5	Important installation information	8
5.1	Conditions of use	8
5.2	Preparation	8
5.3	Mounting aids and required tools	8
5.4	Grounding the mounting system	8
6	Install the system	9
6.1	Using the EPDMs	10
6.2	Placing and aligning the base rails	10
6.3	Positioning of the trapezoidal side fixations	11
6.4	Positioning of the trapezoidal top fixation	12
6.5	Mounting the base rails	12
6.6	Securing the base rails against excessive slipping	14
6.7	Connecting the base rails	14
7	Mounting the modules	15
7.1	Quickstone installation	15
7.2	Anti-slip protection for portrait orientation	16
7.3	Fixing the outer modules of each row	16
7.4	Fixing the inner modules of each row	17
7.5	Installing further rows of modules	17
8	Distinctive features when installing the modules in landscape orientation	18
8.1	Correct alignment of the base rails	19
8.2	Installation of the base rails and modules	20

1 Introduction

1.1 Short description

The SunTop Trapeze flat roof system is a sturdy frame system for mounting PV modules on trapezoidal sheet metal roofs. It consists of aluminum base rails and all necessary small parts to install the modules to the rails and connecting the components to each other. Both portrait and landscape mounting of the modules are possible.

1.2 Intended use

The on-roof system SunTop Trapeze is to be used for the installation of PV modules only. Any other use is considered improper. Please follow the instructions in this manual carefully. Mounting Systems is not responsible for damage that results from improper installation. Be sure to follow the safety and use guidelines closely.

1.3 Standards and guidelines

When planned correctly, SunTop Trapeze fulfills the following standards and directives:

- Eurocode 9 — DIN EN 1999-1-1: Design of aluminum structures
- Eurocode 1 — DIN 1055 — Actions on structures
- DIN 18807-3 Trapezoidal sheeting in building; trapezoidal steel sheeting; structural analysis and design
- DIN 18807 Trapezoidal sheeting in buildings - Part 9: Aluminium trapezoidal sheeting and their connections; application and construction

In addition, every installation must be in compliance with the following codes/rules:

- VDE 0100 – 712 ; IEC 64/1736. Installation of low-voltage systems
- VDE 0185 Serie, IEC 81/335. Lightning protection

1.4 About these instructions

Subject

The purpose of this manual is to provide instructions for the installation of the on-roof system SunTop Trapeze. The illustrations in this manual show the installation for framed modules in portrait orientation. The installation in landscape orientation is dealt separately in section 8.

Users

This manual is written specifically for qualified installers who have undergone instructions by the operator and have basic mechanical and trade skills.

Orientation aids

The following aids will improve the readers' understanding when using this manual:

Symbols



Shows detail and additional information for handling procedures.

Useful Tips



Simplifies handling procedures and contributes to the success of the installation.

2 Safety

2.1 Basic safety information

The following basic safety information and warnings are an important part of this manual and needed for safe handling of this product:

- Ensure that the product meets local code requirements prior to mounting and installation.
- Ensure the building must meet the increased code requirements resulting from the PV unit prior to mounting and installation.
- Comply with the relevant safety regulations.
- Wear a hard hat, protective gloves and safety shoes.
- A second person must be present during the entire installation, to provide assistance in the case of accident.
- Keep a copy of this installation manual in the immediate vicinity of the system.

2.2 Information regarding working on roofs

When working on roofs:

- Always follow accident prevention regulations, and if necessary, install guards to protect against falling components.
- Accident prevention regulations require a safety harness or protective scaffolding be used.
- Observe valid local safety regulations.
- Test and verify the load-bearing capacity of all relevant components prior to walking on the roof.
- Use fall protection equipment.
- Use protective equipment, even for simple and quick tasks.
- Always use appropriate lifting equipment. Never carry material up the ladder.

2.3 Warnings

The warnings listed in this manual indicate safety-relevant information. They include:

- Warning symbols
- Key words to indicate the risk level
- Information about the type and source of the risk
- Information about possible consequences if the danger is ignored
- Measures for avoiding risk and preventing injuries or property damage

The key words in the warnings always indicate one of the following risk levels:



Indicates a severe and unusual risk that, if ignored, could lead to serious injury or death.



Indicates a potentially hazardous situation that could lead to serious or moderate bodily injury and property damage.



Indicates a potential hazard that could lead to property damage.

2.4 Operator's responsibilities

The system operator must fulfill the following safety-related obligations:

- Ensure that only persons with basic mechanical and trade skills should be installing this system.
- Ensure that responsible persons must be able to recognize and assess all possible dangers involved in the work assigned to them.
- Ensure that the responsible persons are familiar with all system components.
- Ensure that the installation manual is readily available during the assembly. These installation manual is an integral part of this product.
- Ensure that a project related design layout exists.
- Ensure that the installation manual and especially the warnings are read and understood by the responsible persons prior to assembly.
- Ensure that the permissible conditions of use (see section 3.3) have been upheld. Mounting Systems will not be responsible for damage which results from a violation of these conditions.
- Ensure that the roof construction has the required load-bearing capacity.
- Ensure that the durability of the mounted connections and the roof attachments are guaranteed.
- Ensure that appropriate lifting equipment must be used for the mounting work.
- Ensure that Mounting Systems components are to be used, both for the initial installation and for eventual maintenance or repair later on, otherwise all guarantees will be void.

3 Technical description

3.1 System overview

All system components are listed below. The design of the individual system components may vary.

They are dependent on:

- roof type
- module type
- number of modules
- the onsite conditions

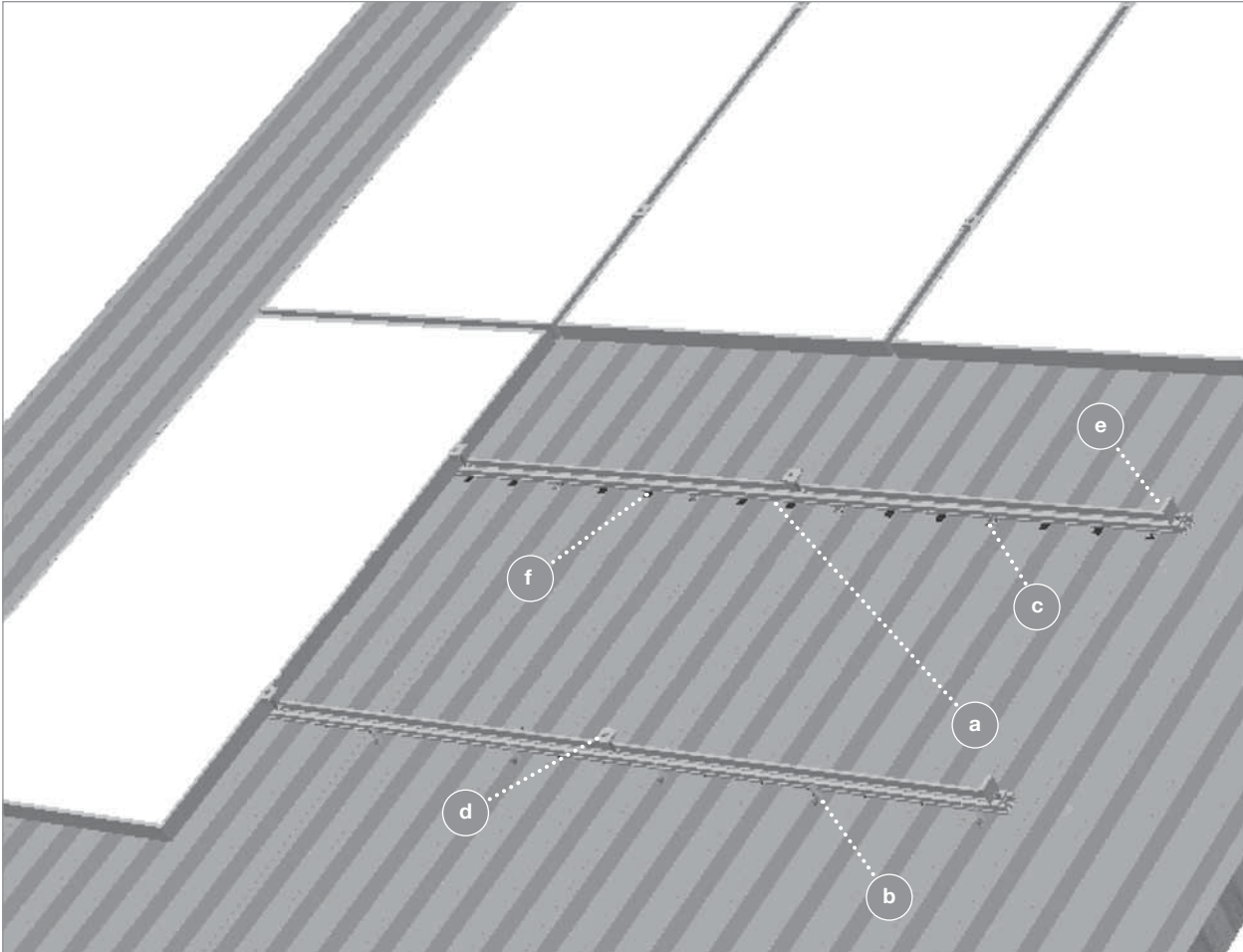

- a Base rail
- b Trapezoidal side fixation
- c Trapezoidal top fixation
- d Inter-module clamp
- e Module end clamp
- f EPDM

Please note:

This illustration shows the portrait orientation of the PV modules. Base rails that are 40 cm long are used for landscape orientation.

In addition, the system overview shows the possibility of fastening the base rails on the side and on the top on the high beads of the corrugation.



a



b



c



d



e



f



g



h



i

3.2 Scope of delivery

Following the descriptions of all SunTop Trapeze components that may be included in delivery are listed. The exact delivery contents and the quantities of the individual system components are based on your order.

- a Base rails
- b Trapezoidal side fixation with Alu-Fixband seal
- c Trapezoidal top fixation
- d Drilling screw with gasket (6x25 mm)
- e Splice preassembled for framed modules
- f EPDM 80 mm (trapezoidal top fixation) or 40 mm (trapezoidal side fixation)
- g Z-Module end clamp
- h Inter-module clamp
- i Grounding clip (Weeb clip)

3.3 Technical specifications

Application areas	Pitched roof – on-roof
Roof covering	Trapezoidal sheet metal ¹
Min. sheet thickness	0,63 mm ²
Min. bead height	Free ³
Roof pitch	Up to 20° ⁴
Height of building	Up to 20 m ⁴
PV module	Framed
Module alignment	Portrait, landscape
Size of the module field	Free ⁵
Position of the module field	Free
Possible height leveling	Up to 5 mm
Distance between rail fixation	Depending on the load situation (automatic verification by the design software)
Standards	Eurocode 1 – DIN 1055 – Actions on structures Eurocode 9 – Design of aluminum structures
Profiles	Extruded aluminum profiles (EN AW 6063 T66)
Rail fixation	Aluminum (EN AW 5754)
Small parts	Stainless steel (V2A)
Color	Aluminum, cold pressed

1 Not suitable for sandwich roofs.

2 After contacting Mounting Systems and a verification of the codes, thinner sheet metal thicknesses may be possible.

3 In case of a very low bead height (below 20 mm) a holder can be screwed on top of the trapezoidal sheet, alternative to the trapezoidal side fixation, which is fixed laterally.

4 Depending on the location, building, selected fixing devices and the module type, other values may vary. With the SunTop Trapeze design tool, you can calculate the permissible maximum values for any system quickly and easily.

5 Because of the expected thermal expansion due to temperature differences and the resulting stress on the rails, we recommend a maximum length of 12 m per module row.

4 Planning the module area

The following gives the spacing of the roof mounts for installing modules that are in a portrait orientation. The spacing for landscape orientation can be found in section 8. The trapezoidal fixation must be mounted at specific distances depending on the material, thickness of the trapezoidal sheet metal, the spacing of the high bead of the corrugation, consideration of the edge area and the further general conditions* (a tool is used for the design).

Taking the above mentioned points into consideration, the trapezoidal fixation must be placed so that they are as close as possible to the module clamps.

When positioning, please note that

- the given dimensions are guidelines.
- the dimensions of the trapezoidal sheet metal and the high bead of the corrugation define the true horizontal spacing.

* A design in accordance with the local conditions according to Eurocode 1-DIN 1055 / Eurocode 9-DIN EN 1999-1-1 is required.

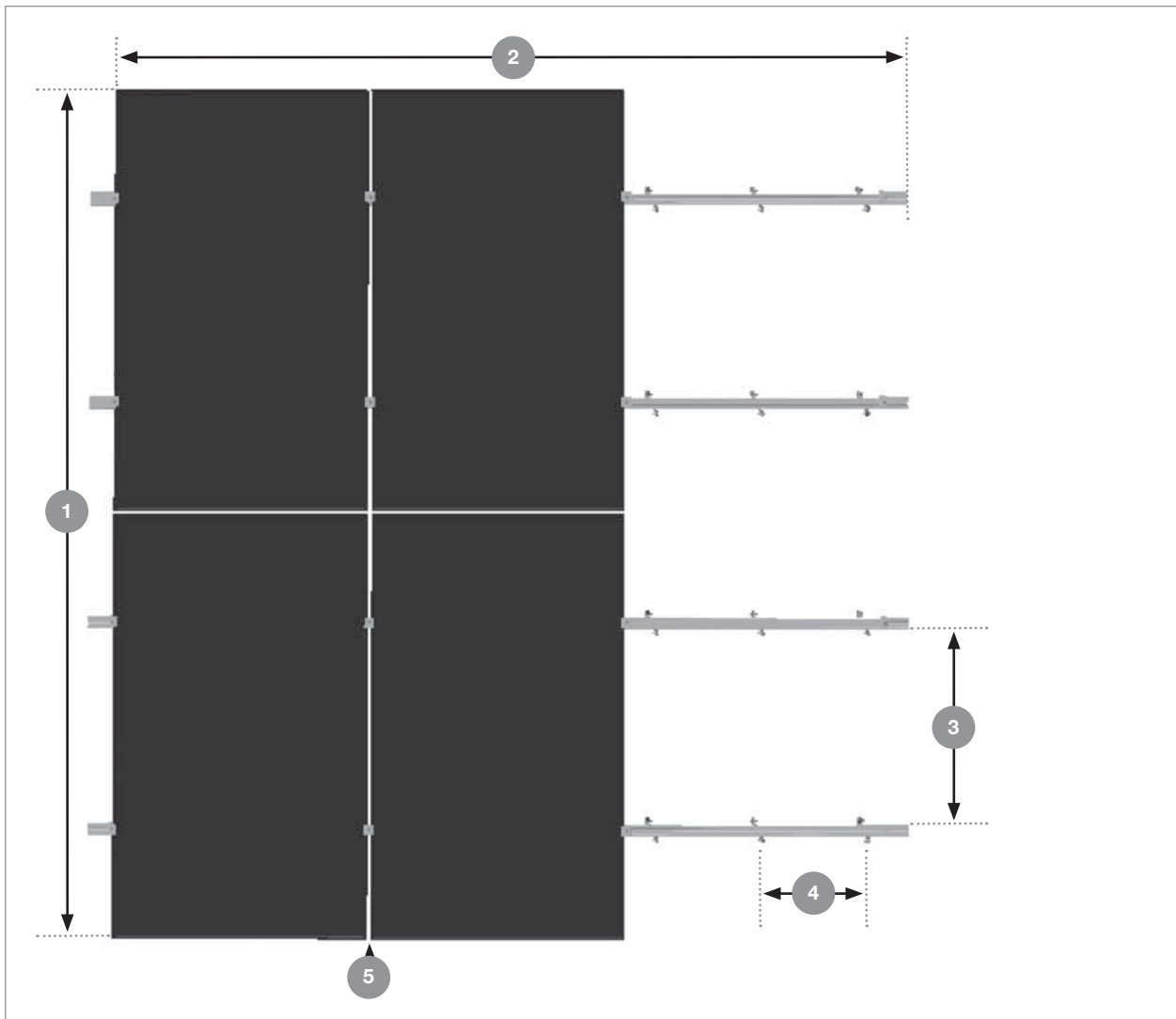

1. Height of the module field: number of modules in the vertical x module height
2. Width of the module field: Number of modules in the horizontal x (module width + 19 mm) + 50 mm
3. Spacing of the guide rails in the vertical (in accordance with the clamping points defined by the module manufacturer): approx. the quarter points of the modules = $1/2 \times$ module height
4. Spacing of the trapezoidal fixations in the portrait orientation: according to the plan, depending on the trapezoidal sheet metal and the structural analysis*
5. Spacing between the modules = 17 – 19 mm

5 Important installation information

5.1 Conditions of use

The on-roof system SunTop Trapeze with its different rail and roof mounting variations is designed for different maximum loads in accordance with Eurocode 1: Actions on structures.

The suitability of the material must be checked for each system, with the help of the SunTop Trapeze design tool.

5.2 Preparation

Mounting Systems recommends that you familiarize yourself with the local conditions prior to ordering SunTop Trapeze.

Pay special attention to the following:

- the roof configuration (e.g. high corrugation bead spacing and bead height)
- the thickness as well as the material of the trapezoidal sheet metal
- the quality and the condition of the trapezoidal sheet metal
- the adequate fixation of the trapezoidal sheet metal to the substructure



CAUTION

Material damage due to inadequate fastening

Inadequate fastening of the trapezoidal sheet metal roof to the substructure can lead to material damage.

- Check to see whether the fastening of the trapezoidal sheet metal to the substructure is adequate.

5.3 Mounting aids and required tools

You will need the following tools to mount the frame system:

- 6 mm Allen key
- Cordless screwdriver
- Attachment for cordless screwdriver, hexagonal 8 mm bit
- Angle grinder with metal disk
- Chalk line
- Spirit level
- Folding rule/measuring tape
- Lifting device
(e.g. attachable work platform, shoulder straps)
- Suction cup tool
- Spacing template if applicable
(for landscape installation)

5.4 Grounding the mounting system

The potential equalization between the individual system components must follow the respective country-specific regulation. A possibility of grounding the SunTop Trapeze system is shown in the following picture. The cable gauges as well as the general grounding concept are not included in this guide and must be calculated and/or created by the installer in accordance with the applicable standards and guidelines. Professional grounding methods other than the ones given here are also possible.

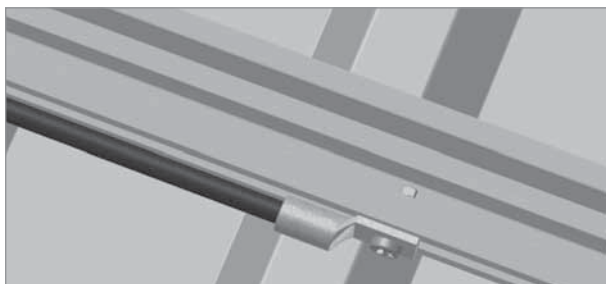

Grounding of the individual rail rows:

- Fasten a cable lug by means of a drilling screw to each row of rails. It can be fastened to the side channel of the base rails. When positioning the cable lug, make sure that it does not adversely affect the use of the trapezoidal fixations, splices or module clamps.
- Connect the individual rows of rails.

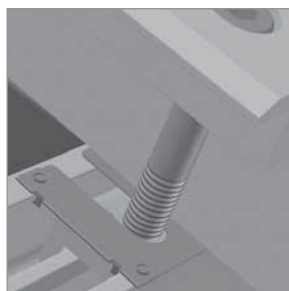
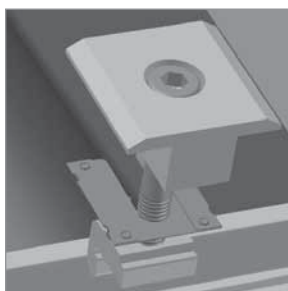

Low-resistance connection between the modules and base rails:

Unless otherwise specified by the module manufacturer, the modules for SunTop Trapeze can be connected conductively to the rails in the following way:

- Slide a grounding clip (weeb clip) onto the still uninstalled module clamp (only inter-module clamps).
- Mount the module clamps as usual, but make sure the grounding clip (weeb clip) is correctly inserted at the same time. The correctly inserted clip sits between the base rail and the module frame. The 4 noses protrude into the rail channel.

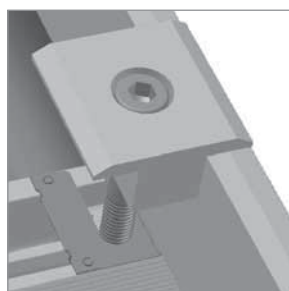

6 Install the system

The following pages contain all the operations for installing the SunTop Trapeze in the correct order. Trapezoidal fixations are used for the assembly of the base rails. They can be fixed either to the side of the high bead of the corrugation or on the high bead itself. Define and mark the position of the individual rows of rails on the roof before beginning assembly.



Material damage by stepping on frame components

CAUTION

Stepping on the roof fixations or base rails may damage the underlying material, e.g. the trapezoidal sheet metal.

- To avoid damaging the underlying material, do not stand on or put any weight on the frame components.



DANGER

Danger to life from falling and falling parts

Falling from the roof or being struck by falling parts may result in critical injuries.

- Protect yourself against falling.
- Do not remain in the danger zone.
- Wear a hard hat.
- After the assembly is complete, check to make sure that the frame system and the modules are secure.

6.1 Using the EPDMs

Installation:

- Define the position of the base rails on the trapezoidal sheet metal, taking into account the allowable clamping area of the used PV modules.
- Use the chalk line to mark the position of the EPDM on each high bead.
- Stick an EPDM strip onto each high bead on which the base rails rests.

EPDM 40x20x1 mm is used for assembling the base rail with the side fixations. EPDM 80x20x1 mm is used for the top fixations.

Make sure that the base rails do not rest on calottes. It might be necessary to adapt the positions of the base rails.

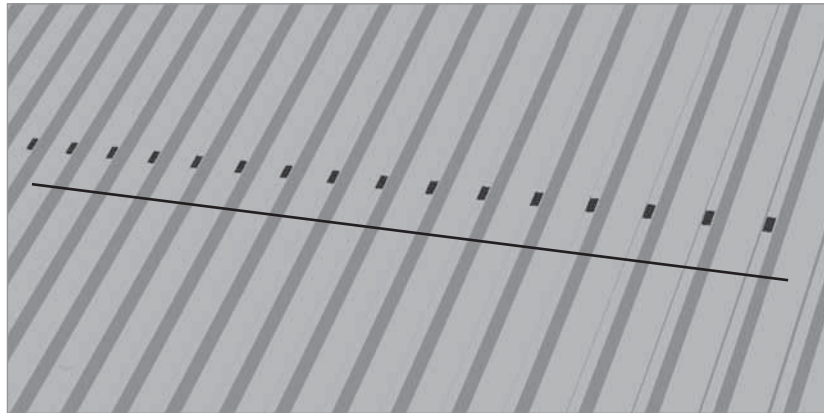

Positioning the EPDMs with the help of a chalk line



CAUTION

Material damage due to incorrect assembly

Resting the base rails on the trapezoidal sheet metal without EPDM can lead to damaging the roofing material.

- Stick an EPDM strip onto every high bead that comes into contact with the base rails.

6.2 Placing and aligning the base rails

Positioning the base rails onto the roof to interpret and define the possible cuts. The connected series of rails should not exceed a length of 12 m. The required total railway length is determined by the width of the module area (see point 4). Make sure that the maximum cantilever of 17.5 cm is not exceeded (if necessary, cut rails or use splices).

The spacing of the rails to each other is defined by the size of the PV module (see section 4).

Base rails that are 40 cm long are used for landscape mounting (see section 8).

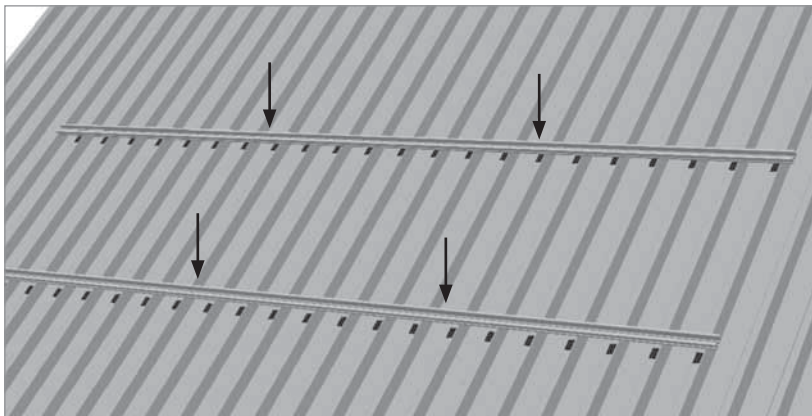

Aligning and placing the profiled rails

Installation:

- Place the base rails on the applied EPDM.
- Using a level, align the profiled rails to each other.

6.3 Positioning of the trapezoidal side fixations

Installation:

- Insert the trapezoidal side fixation in the side channel.
- Press the trapezoidal side fixation against the side of the high bead and make sure that it rests uniformly and is hooked into the side channel of the base rail correctly.
- The trapezoidal side fixations are fastened opposite from each other on the high bead.

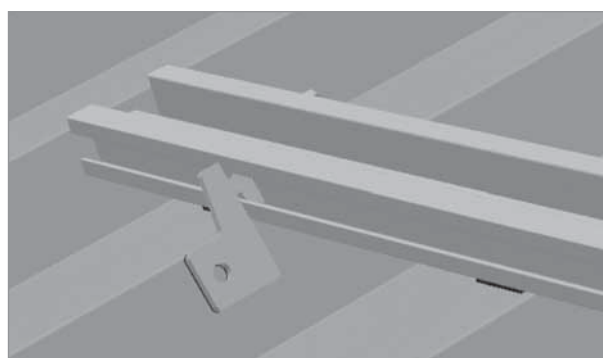
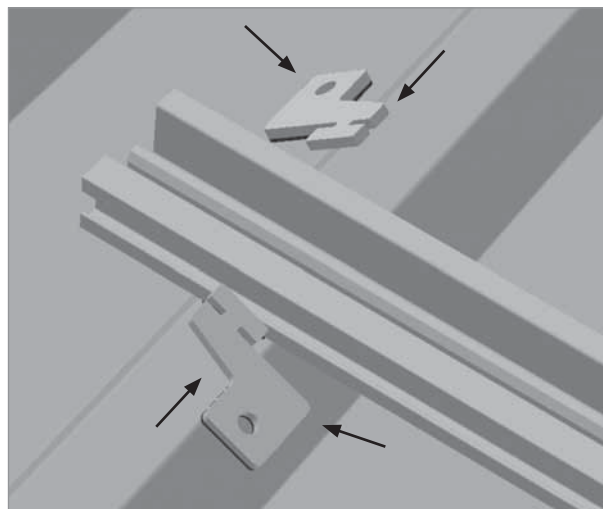

Positioning of the trapezoidal side fixation for bead heights ≥ 20 mm



TOOL

The following points must be considered when installing the trapezoidal side fixations till the verge of the roof.

- It is not possible to place the trapezoidal side fixation set off to one side.
- Fasten the first trapezoidal side fixation on the high bead as described above.
- The second trapezoidal side fixation can only be fastened opposite on the same side of the high bead.
- To do this, pull the sealing off the trapezoidal fixation and stick it on the opposite side. A piece of EPDM can also be used.



CAUTION

Material damage due to incorrect assembly

Incorrectly assembled trapezoidal side fixations may rip out.

- When fastening the trapezoidal side fixations, always make sure that the fixation is seated correctly in the channel.

6.4 Positioning of the trapezoidal top fixation

Installation:

- Place the trapezoidal top fixation onto the EPDM and attach to the profiled rail as shown in above picture.
- Place the opposite trapezoidal top fixation.

Take into account that longer EPDM pieces that are 80x20x1 mm must be used.

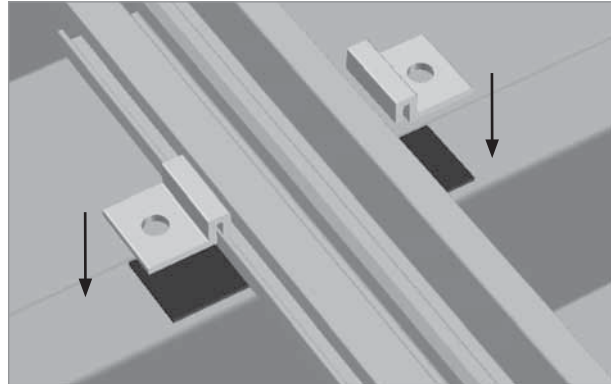

Positioning of the trapezoidal top fixations for bead heights < 20 mm

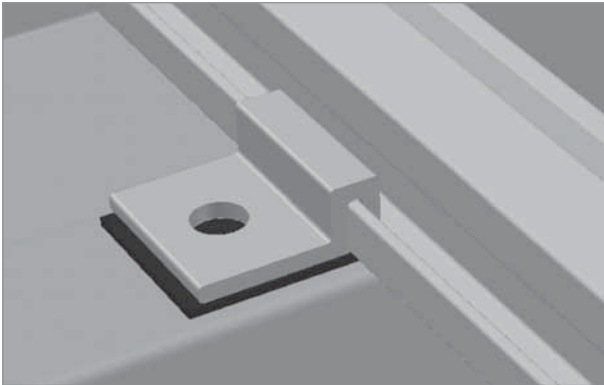

Correct fit of the trapezoidal top fixation



CAUTION

Material damage due to incorrect assembly

Incorrectly assembled trapezoidal fixations may rip out.

- When fastening the trapezoidal fixation, always make sure that the fixation is seated correctly on the base rail.

6.5 Mounting the base rails

Installation:

- Fasten the trapezoidal fixation on the side or top with the supplied 6x25 mm drilling screws with gaskets.
- Do not over-tighten the screws.
- The torque setting of the cordless screwdriver is dependent on the thickness and the material of the trapezoidal sheet metal.

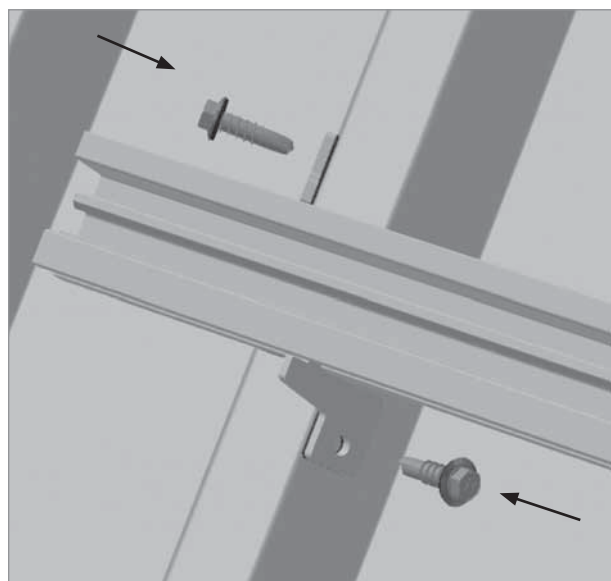

Positioning of the 6x25 mm drilling screw with a gasket

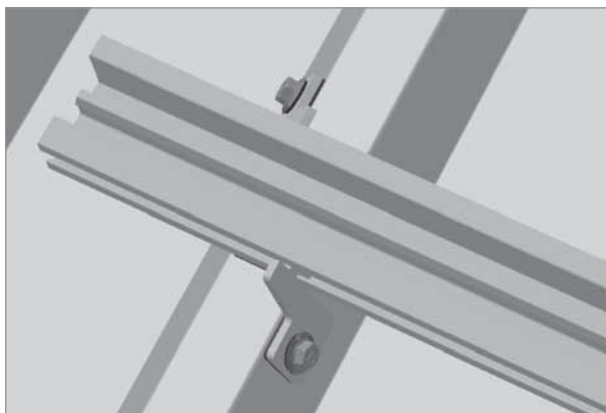

Mounted side trapezoidal fixation

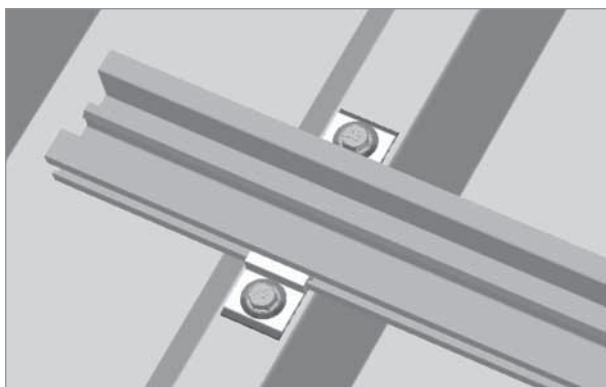

Mounted top trapezoidal fixation



CAUTION

Building damage through leakage

Incorrectly installed trapezoidal fixation and drilling screws can cause leaks.

- Be sure the fixation is evenly aligned on the high bead.
- Make sure that the seal rests cleanly between the high bead and the trapezoidal side fixation.
- Make sure if installing the trapezoidal top fixation the EPDM fits correctly underneath.



CAUTION

Material damage due to incorrect assembly

Incorrectly installed drilling screws may rip out.

- Do not over-tighten the drilling screws.



CAUTION

Damage to the building and the PV system through incorrect frame installation

Incorrect spacing of the trapezoidal fixation can cause damage to the building and the PV system.

- When fastening the base rails with the trapezoidal fixations select the spacing corresponding to the tool configuration.
- Comply with the different configurations for the spacing of the trapezoidal fixations that are to be placed at the edge and in the field area.

6.6 Securing the base rails against excessive slipping

The base rails should be secured in their position. The used trapezoidal fixations allow the base rail an expansion possibility, as e.g. arise from high temperature differences. To secure the position and still allow an expansion of the base rails, they have to be secured with two drilling screws from the side. Rows of rails that are connected together with the Splice only have to be secured once with two drilling screws. Each individual rail must be equipped with two drilling screws.

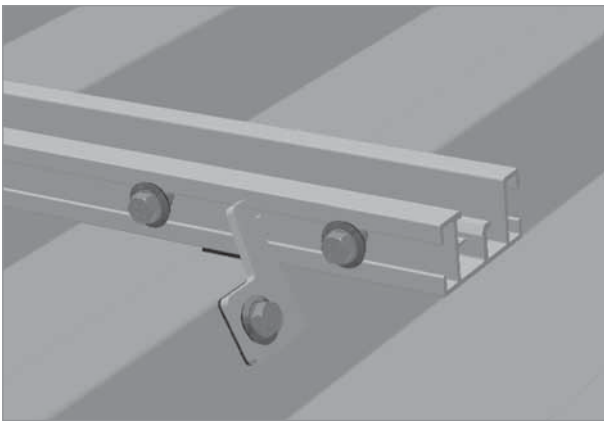

Installation:

- Two 6x25 mm drilling screws (identical to the screws for fastening the trapezoidal fixations) are used to secure the base rails.
- Screw the drilling screws into the side of the base rail to the right and left of the trapezoidal fixation at a distance of approx. 2 cm.
- Ensure that the use of the module clamps or splices is not impeded by the drilling screws.

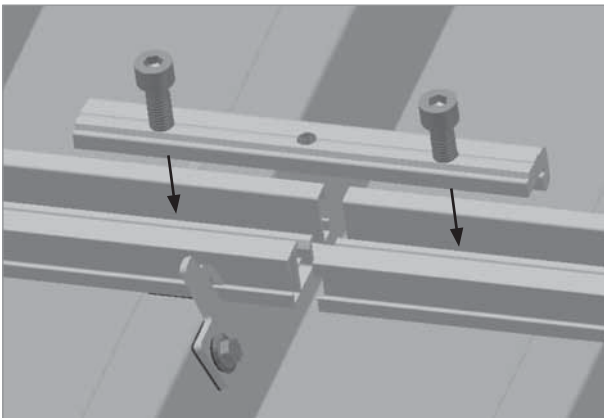
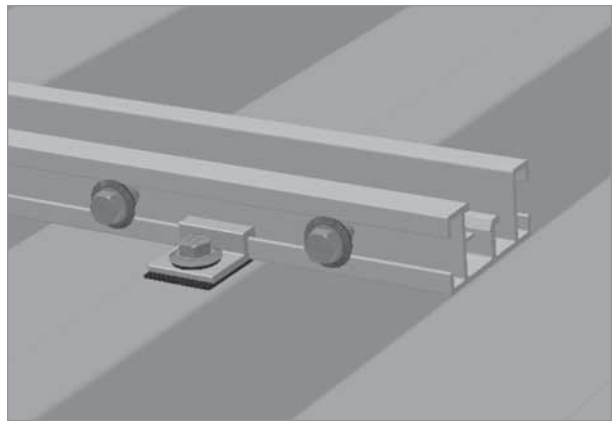

Profiled rail connection with Splice for framed PV modules

6.7 Connecting the base rails

A splice is provided for connecting individual rail series. They can also be used for grounding individual base rails together.

Installation:

- Put the splice into the Quickstone channel from the top.
- Make sure it is seated correctly in the channel.
- Tighten the first M 8 Allen screw (torque=8 Nm) with the Allen wrench.
- Tighten the second M 8 Allen screw (torque=8 Nm) with the Allen wrench.

The connected series of rails should not exceed 12 m in length.

From that point on, an expansion joint (approx. 5 cm) must be used. Do not install any modules over an expansion joint.

7 Mounting the modules

The modules are successively installed onto base rails. It is recommended to start on one side of the module field. The Modules in the bottom row can be equipped with anti-slip protection. Inter-module clamps and module end clamps are used to fasten the modules. The module end clamps can each be used to hold one module. The inter-module clamps are positioned between two modules.

7.1 Quickstone installation

Quickstones are used for the assembly of the modules. A Quickstone is a special profiled nut that is used to fasten the module clamp in the base rail. For the installation, you only need an Allen wrench (6 mm). You can insert Quickstones into the rail channel of the base rail from the top.



DANGER

Danger to life from falling and falling parts

Falling from the roof or being struck by falling parts may result in critical injuries.

- Protect yourself against falling.
- Do not remain in the danger zone.
- Wear a hard hat.
- After the assembly is complete, check to make sure that the frame system and the modules are secure.

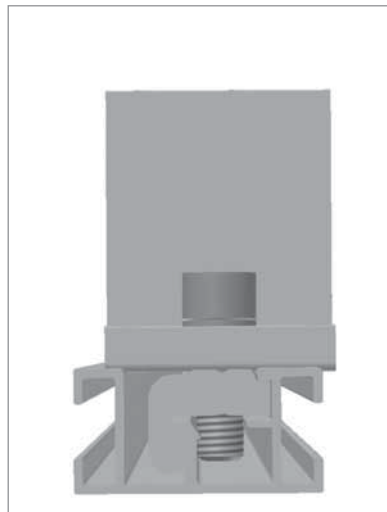
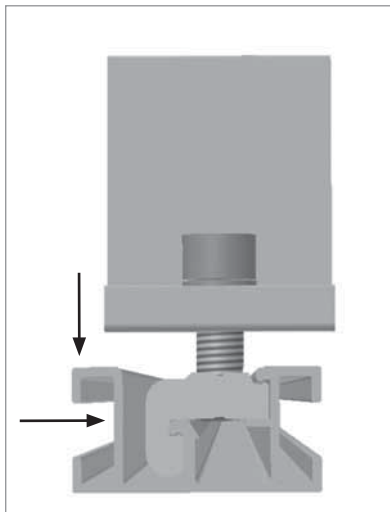

Installation:

- Loosen the Allen screw before the installation, without removing it completely. The Allen bolt must not protrude past the bottom of the Quickstone.
- Insert the Quickstone into the channel. The shape of the Quickstone fits precisely into the profile of the Quickstonechannel.
- Tighten to 8 Nm with the Allen wrench.



CAUTION

Material damage due to incorrect assembly of the Quickstones

Incorrectly installed Quickstones may rip out of the profile.

- Install all Quickstone connections in accordance with the instructions.

7.2 Anti-slip protection for portrait orientation

Installation:

- The anti-slip protection is only necessary for modules in the bottom row.
- Install one anti-slip protection (M 6 x 20 mm bolt with nut) in each of the lower holes of the module.
- Place the first module of the bottom row so that the anti-slip protection sits in the rail channel of the lowest rail row.

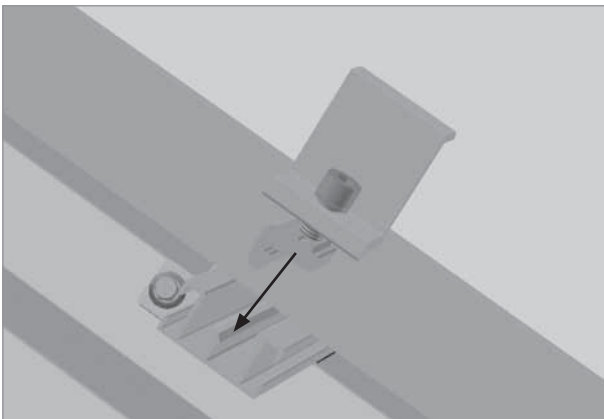
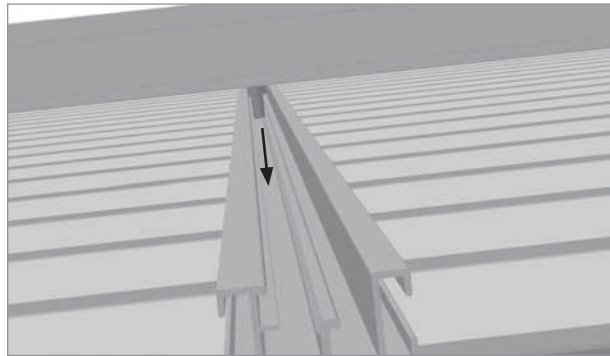
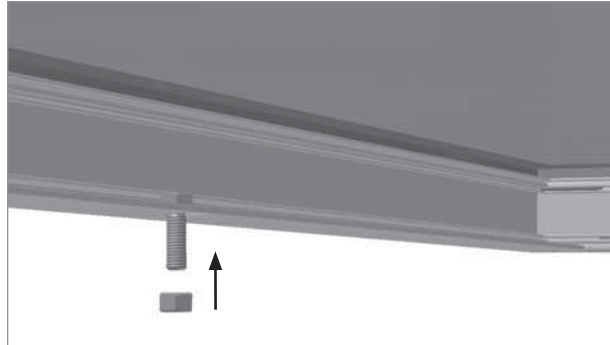

7.3 Fixing the outer modules of each row

Installation:

- Insert the Quickstone of the module end clamp (Z-module end clamp here in the example) in the rail channel of the base rail. When positioning, the Allen bolt must not protrude past the underside of the Quickstone.
- Insert and align the module.
- Clamp the module under the module end clamp and tighten the Allen bolt (torque=8 Nm).

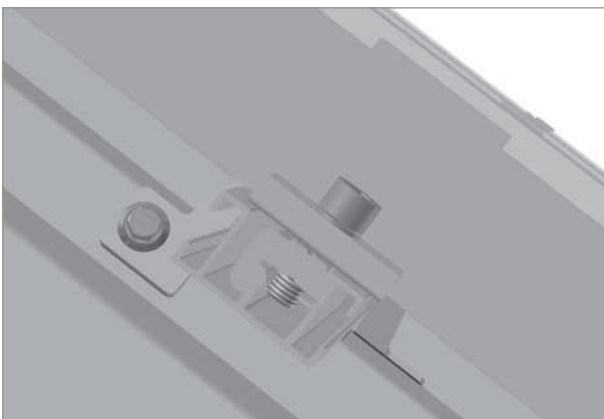

7.4 Fixing the inner modules of each row

Installation:

- Insert the Quickstone of the inter-module clamp into the rail channel of the base rail and slide it onto the mounted module.
- Align the second module to the module clamp and tighten the Allen bolt (tightening torque 8 Nm).

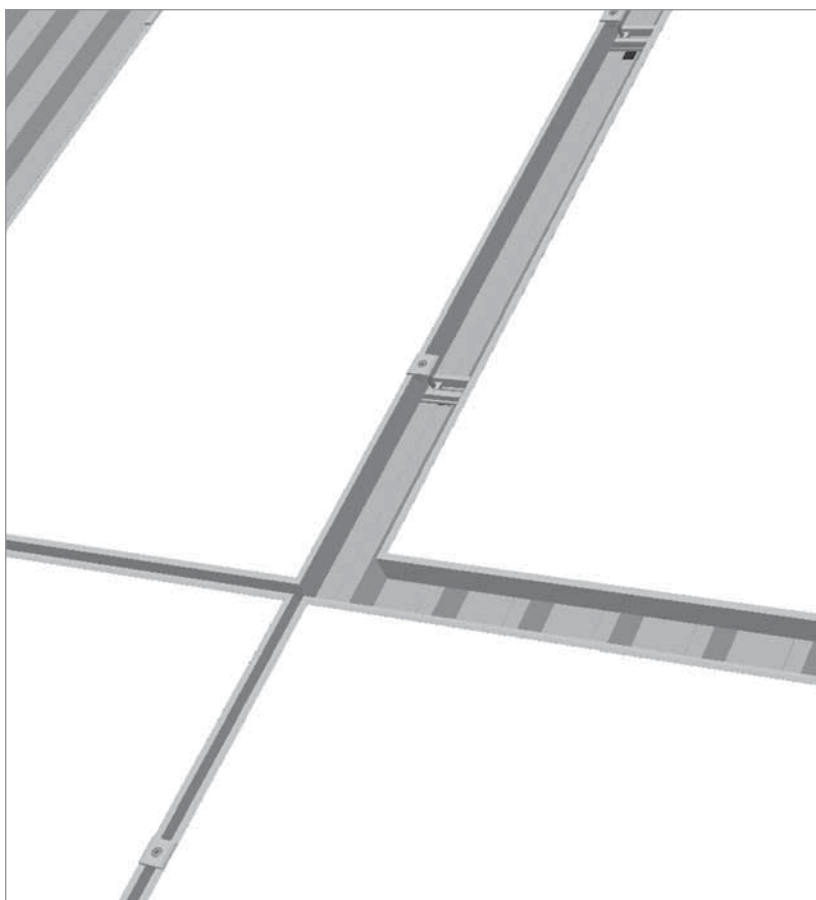
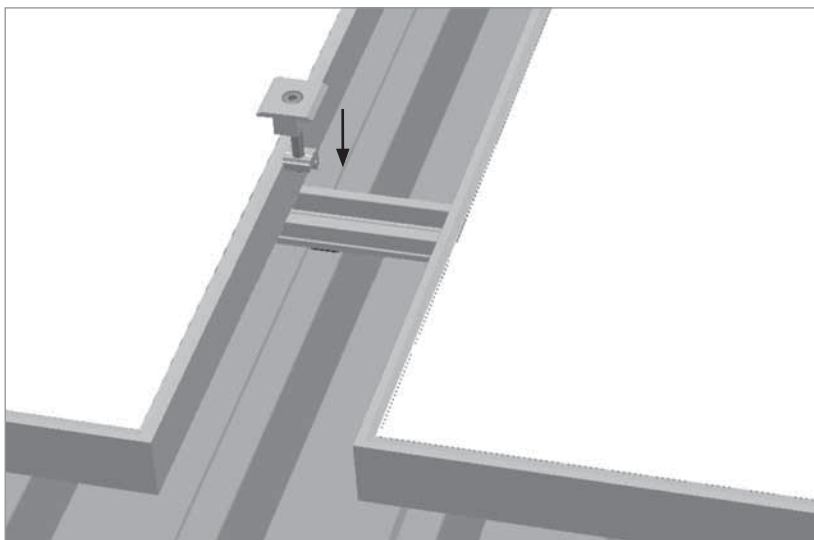

7.5 Installing further rows of modules

Installation:

- Align the modules of the top row with the bottom row, being sure to keep the space between them even.



TOOL

You may use a inter-module clamp, for example, as a spacing gauge. You will obtain identical spacing horizontally and vertically using this technique.

- Fasten the modules with the module end clamps and inter-module clamps identical to the first row (see section 7.3 and 7.4)

8 Distinctive features when installing the modules in landscape orientation

The spacing is determined by the dimensions of the modules to be installed. Ensure compliance with the clamping points stipulated by the manufacturer.

The spacing of the base rails is determined as follows:

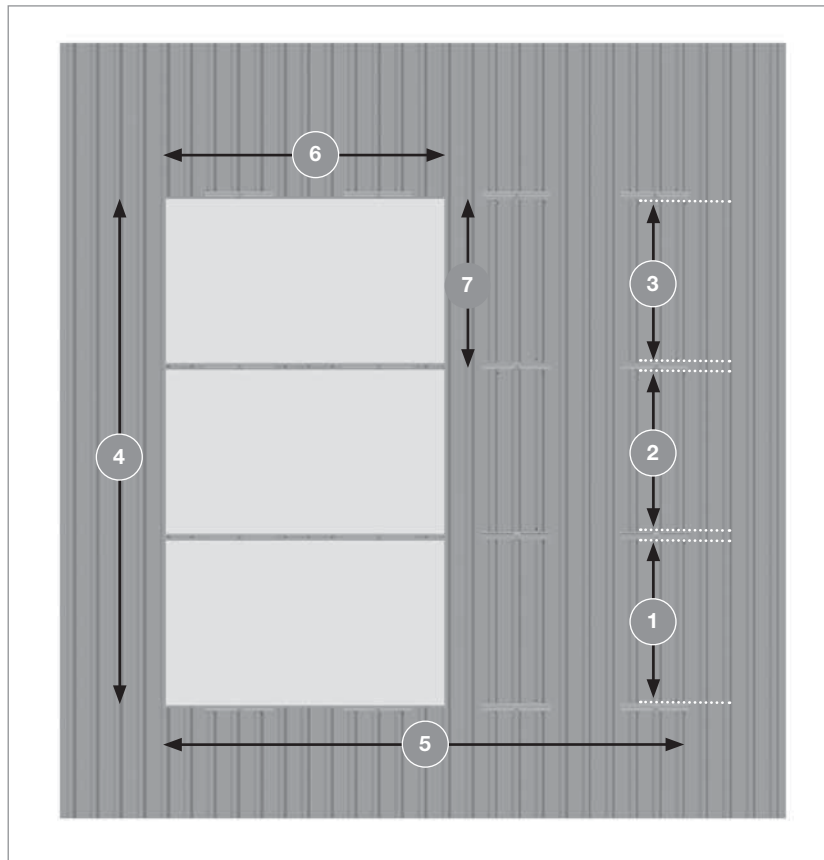
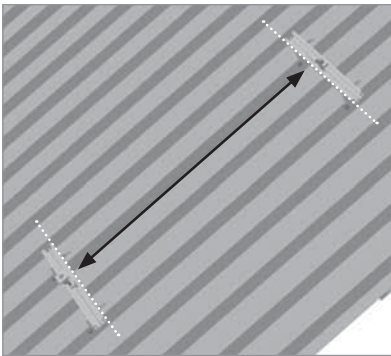

DANGER

Danger to life from falling and falling parts

Falling from the roof or being struck by falling parts may result in critical injuries.

- Protect yourself against falling.
- Do not remain in the danger zone.
- Wear a hard hat.
- After the assembly is complete, check to make sure that the frame system and the modules are secure.

1. Distance between the bottom two rail segments: width of the module minus 20 mm +/- 2 mm (inside width)
2. Distance between the middle rail segments: width of the module minus 23 mm +/- 2mm (inside width)
3. Distance between the top two rail segments: width of the module minus 28 mm +/- 2mm (inside width)
4. Height of the module field:
Number of modules in the vertical x (module width + 19 mm) + 50 mm
5. Width of the module field: number of modules in the horizontal x module height
6. Module height
7. Module width

The values for points 1-3 each refer to the inside width between the rails (see picture above).



INFO

Base rails that are 40 cm long are used for installing the modules in landscape orientation. Here you must be careful to maintain the correct spacing between the base rails. Accuracy is a must. Mounting Systems recommend using a spacing template to maintain the correct spacing. Precise rail alignment must be maintained. Take into account that the rail row near to the roof ridge is mounted always turned by 180°.

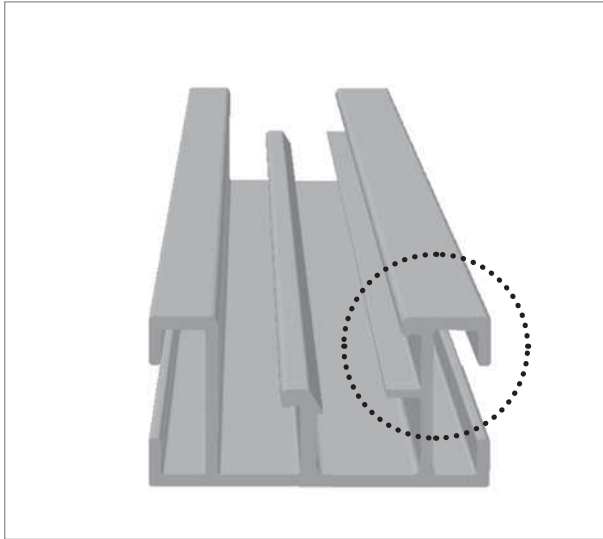

8.1 Correct alignment of the base rails

Correct alignment of the 40-cm-long rail segments is mandatory!

Align the profiled rails as follows:

During the alignment, the wider flat surface of the base rail with the nose can be used as an orientation aid.

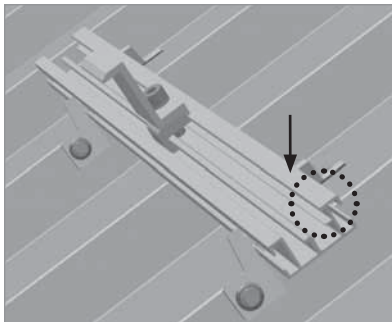

Uppermost rail

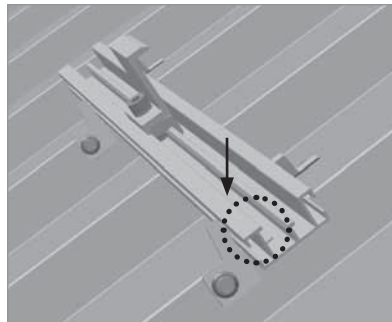

Bottommost rail

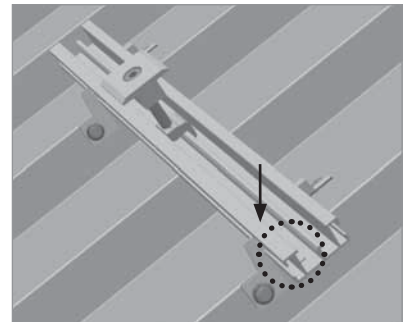

Middle rails

Position the top row of base rails as shown in figure 1. The wider flat surface of the base rail can be used as an orientation aid. It must face the direction of the roof ridge. The other rows of rails are mounted with the wide flat surface facing down.

8.2 Installation of the base rails and modules

Installation:

- Mark the positions of the base rails.
- Apply the EPDM on all necessary high beads.
- Align (use a spacing template) and fasten the base rails with the trapezoidal fixation.
- Installation of the modules.

For landscape mounting, the Quickstone must be placed in the channel at the side of the profile. It is not possible to insert the Quickstone into the channel from the top.



For further information:

www.conergy.com

Subject to technical modifications without notice.
2011 © Conergy